

TS-200 / 220 series Installation process

Step 1.

Before installation, make sure to cut completely the "Short -Wire"

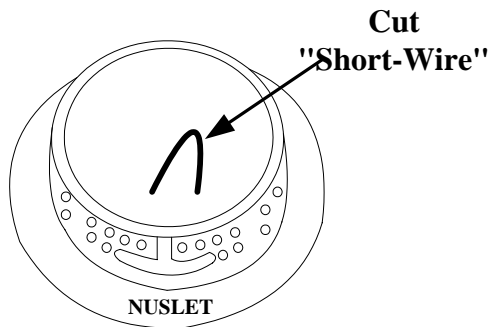

Step 2.

Dig a core of about 110mm in Diameter and 60mm in depth. Do not dig too much because the Epoxy or Premix cement will not be enough.

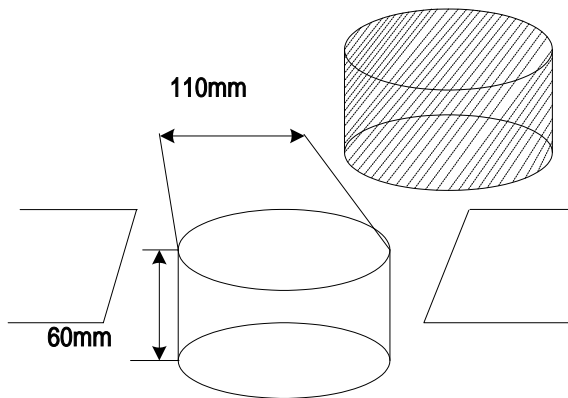

Step 3.

Remove excess water completely from the core with sponge etc. Sometimes use a burner for drying if necessary

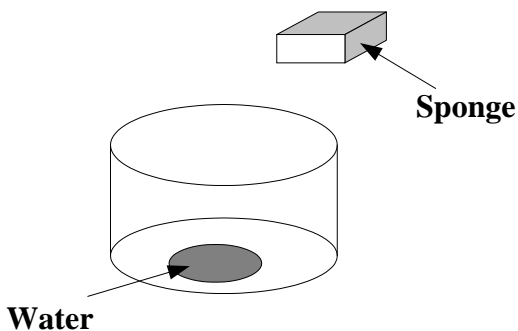

Step 4.

Pour the mixed Epoxy or cement into the core until 30mm below the road surface.

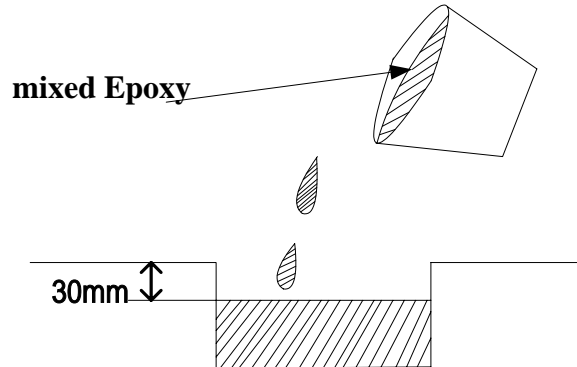

Step 5.

Push the product into the core. If the product is floating, put something heavy such as the digger core on top of it

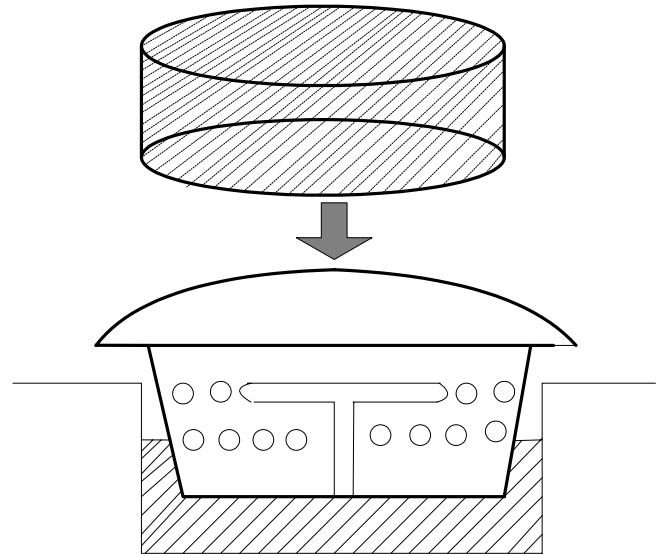

Step 6.

Clean the displaced Epoxy or cement with a wire-brush or sponge. After installation, take off the masking film

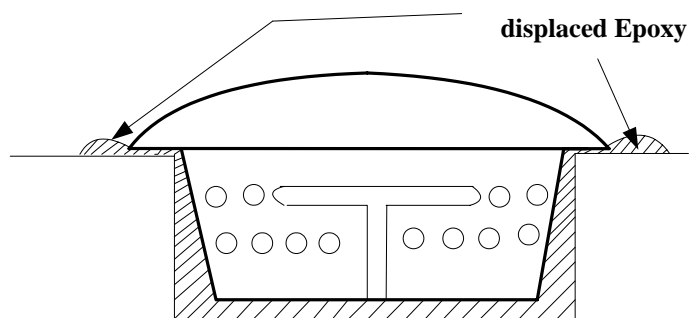

P.S. If the Epoxy does not get displaced on the road surface, take the body out and pour more Epoxy in again.